

# DME33

MODEL CODE	VOLTAGE	OUTPUT	CURRENT
SA	12V	0.7W	0.12A
SB	24V	0.7W	0.06A
BA	12V	3.0W	0.42A
BB	24V	3.0W	0.22A



## ● DIMENSIONS Unit mm(inch)

### DME33SA, DME33SB

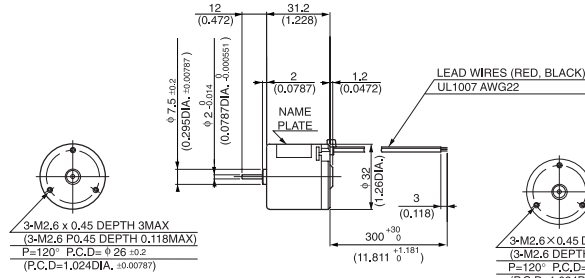

### DME33BA, DME33BB

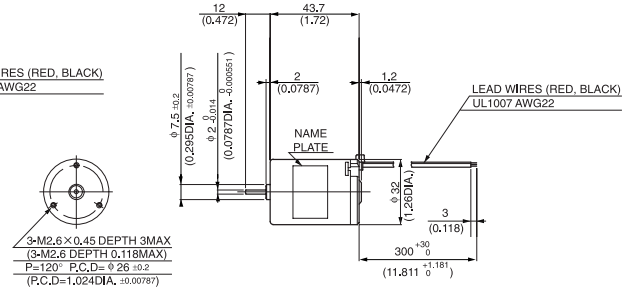

## ● CURRENT, SPEED-TORQUE CURVE

### DME33SA, DME33SB

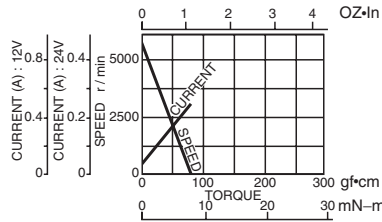

### DME33BA, DME33BB

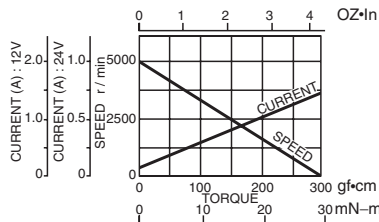

## ● CONNECTION

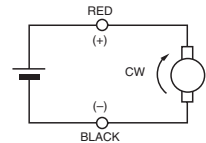

## ● STANDARD SPECIFICATIONS

Model	Rated					No load		Stall torque		Weight		
	Output W	Voltage V	Torque		Current A	Speed r/min	Current A	Speed r/min	mN·m	oz·in	Weight	
			mN·m	oz·in							g	lb
DME33SA	0.7	12	1.5	0.21	0.12	4500	0.05	5500	7.8	1.11	70	0.15
DME33SB	0.7	24	1.5	0.21	0.06	4500	0.02	5500	7.8	1.11	70	0.15
DME33BA	3	12	7.8	1.11	0.42	3700	0.06	5000	29	4.17	100	0.22
DME33BB	3	24	7.8	1.11	0.22	3700	0.04	5000	29	4.17	100	0.22

## ● REVOLUTION SENSOR MAGNET TYPE

### DME33SMA, DME33SMB

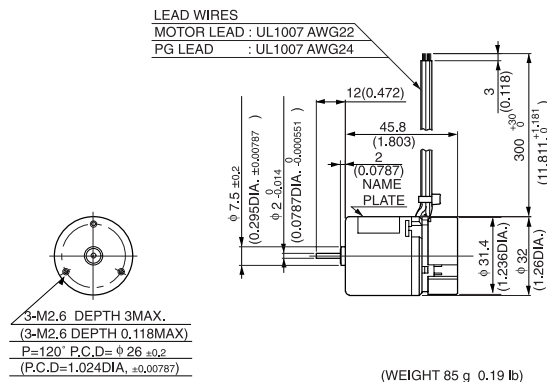

### DME33BMA, DME33BMB

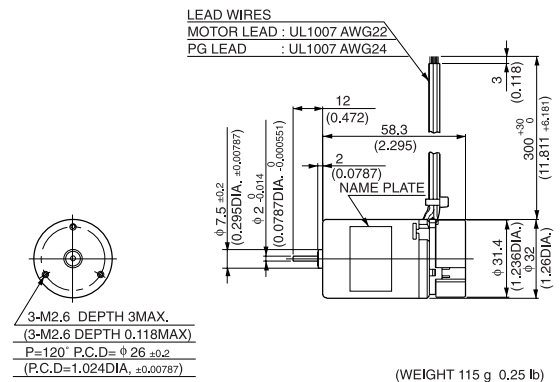

## ● CONNECTION OF REVOLUTION SENSOR

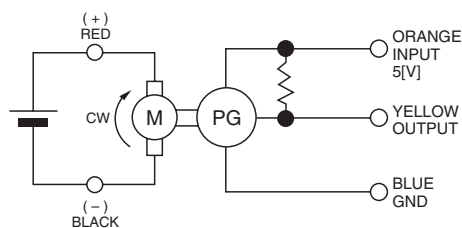

## ● SPECIFICATION OF REVOLUTION SENSOR SHOWN ON PAGE 8.

# DME33

MODEL CODE	VOLTAGE	OUTPUT	CURRENT
SA	12V	0.7W	0.12A
SB	24V	0.7W	0.06A
BA	12V	3.0W	0.42A
BB	24V	3.0W	0.22A

## WITH GEARBOX 50G



50G

### ● DIMENSIONS Unit mm(inch) DME33B50G

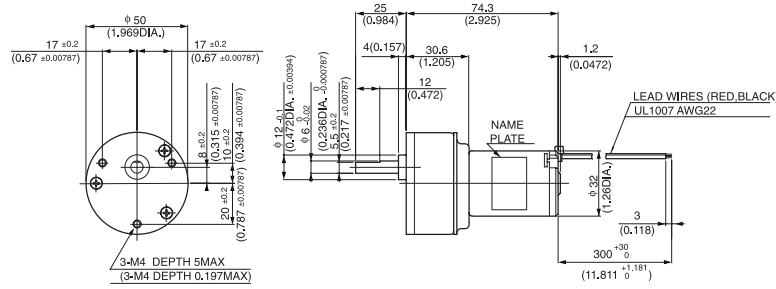

(WEIGHT 300g 0.66 lb)

### ● with 50G TYPE GEARBOX

Model	Gear ratio		9	18	*27	*36	*54	*72	96	144	192	256
	Rated speed	r/min	411	205	137	102	68.5	51.3	38.5	25.7	19.3	15.7
DME33B50G <input type="checkbox"/> ☆	Rated torque	N-m	0.057	0.11	0.15	0.21	0.3	0.41	0.49	0.74	0.98	0.98
		oz-in	8.05	15.28	20.83	29.16	43.05	58.33	69.44	104.15	138.87	138.87

## WITH GEARBOX L

Gear heads for  
intermittent drive



L

### ● DIMENSIONS Unit mm(inch) DME33SL

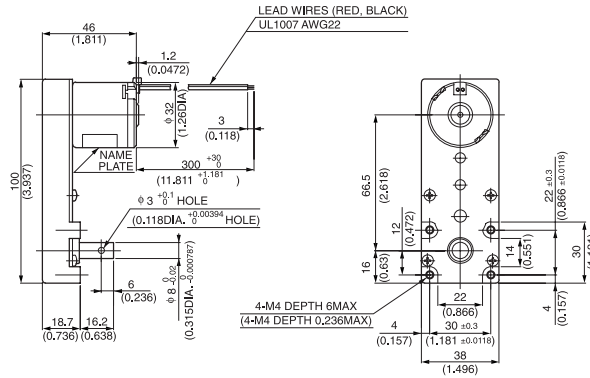

(WEIGHT 240 g 0.53 lb)

### DME33BL

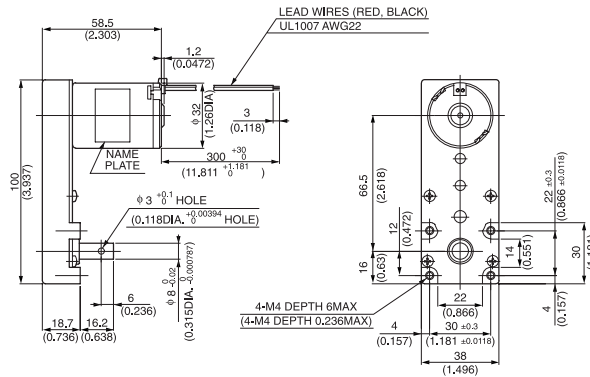

(WEIGHT 270 g 0.6 lb)

### ● with L TYPE GEARBOX

Model	Gear ratio		30	50	120	150	200	255
	Rated speed	r/min	150	90	37.5	30	22.5	17.6
DME33SL <input type="checkbox"/> ☆	Rated torque	N-m	0.025	0.043	0.098	0.13	0.17	0.22
		oz-in	3.61	6.11	13.89	18.05	23.61	30.55
DME33BL <input type="checkbox"/> ☆	Rated speed	r/min	139	83.7	34.9	27.9	20.9	16.4
		N-m	0.086	0.14	0.34	0.43	0.58	0.74
		oz-in	12.22	19.44	48.61	61.10	81.93	104.15

NOTE 1: Enter the required reduction ratio in the .  
2: \*Rotation of gearbox shaft is in reverse of rotation of motor.  
3: Enter the required voltage A or B in the ☆.