

DME34

MODEL CODE	VOLTAGE	OUTPUT	CURRENT
SA	12V	1.3W	0.2A
SB	24V	1.3W	0.1A
BA	12V	4.5W	0.65A
BB	24V	4.5W	0.31A
KB	24V	7W	0.41A

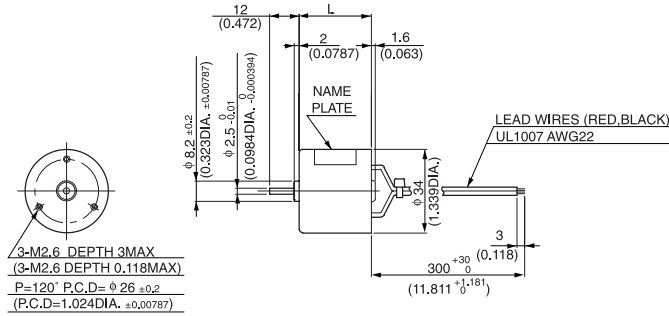

● DIMENSIONS Unit mm(inch)



Model	L	Weight	
		g	lb
DME34SA	29.5	100	0.22
DME34SB	29.5	100	0.22
DME34BA	35.0	110	0.24
DME34BB	35.0	110	0.24
DME34KB	45	140	0.31

● CONNECTION

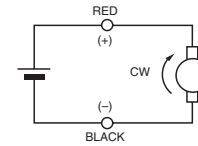

● CURRENT, SPEED-TORQUE CURVE

DME34SA, DME34SB

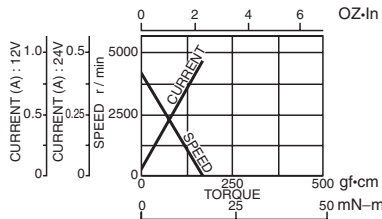

DME34BA, DME34BB

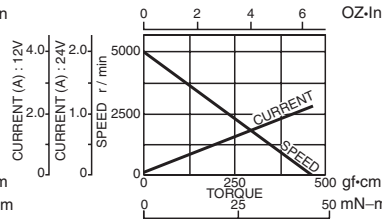

DME34KB

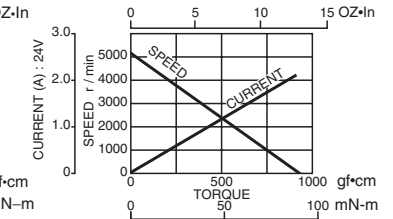

● STANDARD SPECIFICATIONS

Model	Rated					No load		Stall torque		
	Output W	Voltage V	Torque		Current A	Speed r/min	Current A	Speed r/min	mN·m	oz·in
			mN·m	oz·in						
DME34SA	1.3	12	3.9	0.56	0.2	3300	0.04	4300	17	2.36
DME34SB	1.3	24	3.9	0.56	0.1	3300	0.02	4300	17	2.36
DME34BA	4.5	12	11.8	1.67	0.65	3700	0.07	5000	45	6.39
DME34BB	4.5	24	11.8	1.67	0.31	3700	0.04	5000	45	6.39
DME34KB	7	24	14.7	2.08	0.41	4300	0.06	5100	92	13.03

● REVOLUTION SENSOR MAGNET TYPE

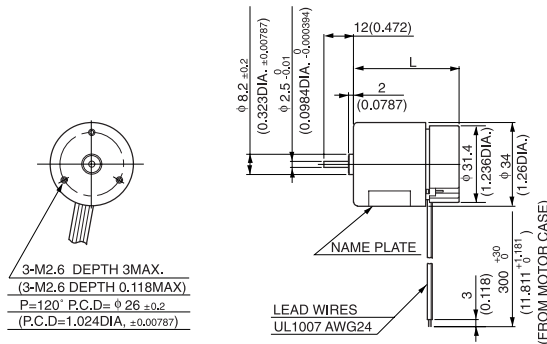

Model	L	Weight	
		g	lb
DME34SMA	43.1	110	0.24
DME34SMB	43.1	110	0.24
DME34BMA	48.6	120	0.26
DME34BMB	48.6	120	0.26
DME34KMB	58.6	150	0.33

DME34

MODEL CODE	VOLTAGE	OUTPUT	CURRENT
SA	12V	1.3W	0.2A
SB	24V	1.3W	0.1A
BA	12V	4.5W	0.65A
BB	24V	4.5W	0.31A
KB	24V	7W	0.41A

● REVOLUTION SENSOR OPTICAL TYPE

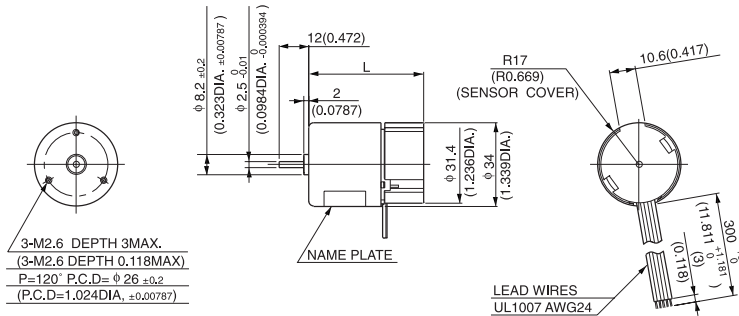

Model	L	Weight	
		g	lb
DME34SEA	47.1	120	0.26
DME34SEB			
DME34BEA	52.6	130	0.29
DME34BEB			
DME34KEB	62.6	160	0.35

● CONNECTION OF REVOLUTION SENSOR

DME34SMA, DME34SMB, DME34BMA, DME34BMB
 DME34SEA, DME34SEB, DME34BEA, DME34BEB

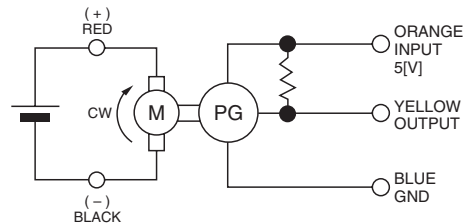

● SPECIFICATION OF REVOLUTION SENSOR ARE SHOWN ON PAGE 8.

WITH GEARBOX
36G

Gear heads for
 intermittent drive



36G

● DIMENSIONS Unit mm(inch)

DME34S36G

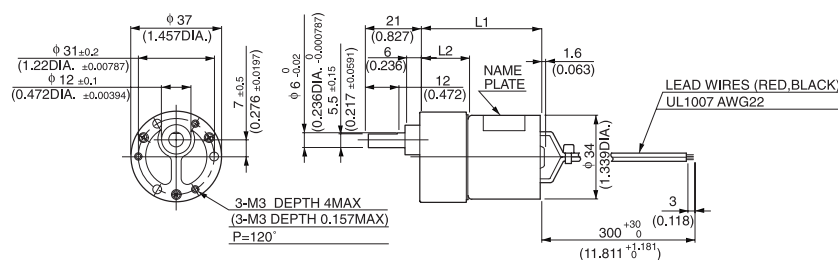

GEAR RATIO	L1		L2		WEIGHT	
	(mm)	(inch)	(mm)	(inch)	g	lb
10	49.3	1.941	19.8	0.78	200	0.44
18~30	51.8	2.039	22.3	0.878		
50~100	54.3	2.138	24.8	0.976		
120~300	56.8	2.236	27.3	1.075	220	0.49
400~600	59.3	2.335	29.8	1.173		

DME34

WITH GEARBOX
8DG



8DG

MODEL CODE	VOLTAGE	OUTPUT	CURRENT
SA	12V	1.3W	0.2A
SB	24V	1.3W	0.1A
BA	12V	4.5W	0.65A
BB	24V	4.5W	0.31A
KB	24V	7W	0.41A

●DIMENSIONS Unit mm(inch)
DME34B8DG

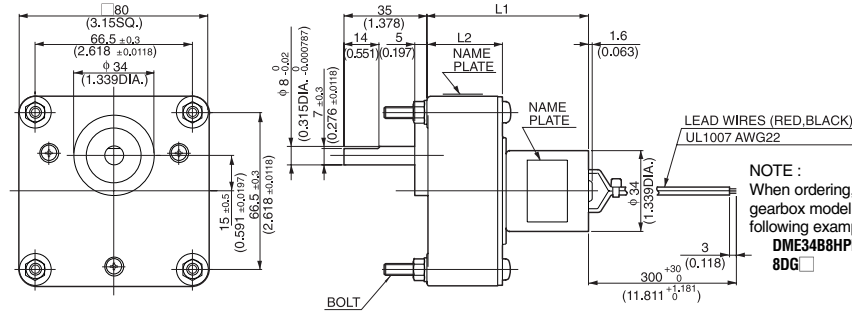

NOTE :
When ordering, please write the motor model and gearbox model numbers separately, as in the following example:
DME34B8HPB (Pinion shaft motor)
8DG (Gearbox)

GEAR RATIO	L1		L2		BOLT		WEIGHT	
	(mm)	(inch)	(mm)	(inch)	(mm)	(inch)	kg	lb
30~150	68.5	2.697	32	1.26	M5X50	M5X1.969	0.61	1.34
250~1800	78.5	3.090	42	1.65	M5X60	M5X2.362	0.71	1.56

●DIMENSIONS Unit mm(inch)
DME34K8H

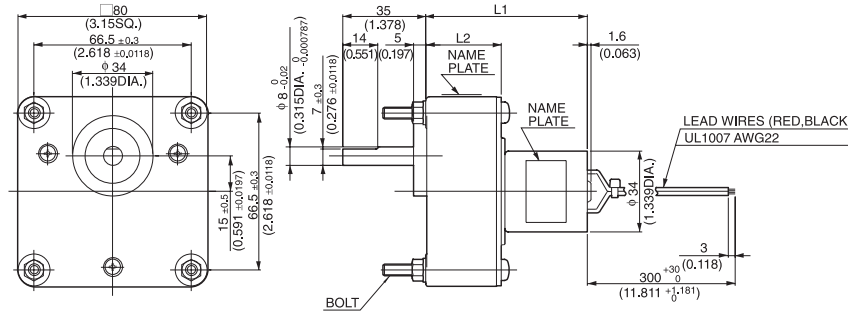

GEAR RATIO	L1		L2		BOLT		WEIGHT	
	(mm)	(inch)	(mm)	(inch)	(mm)	(inch)	kg	lb
30~150	78.5	3.090	32	1.26	M5X50	M5X1.969	0.75	1.65
250~1800	88.5	3.484	42	1.65	M5X60	M5X2.362	0.85	1.87

●with 8DG TYPE GEARBOX MOTOR MODEL **DME34B8HP**☆ & GEARBOX MODEL **8DG**□

Model	Gear ratio	*30	*50	*75	*100	*150	250	300	*500	*750	*1800	
												Rated speed
DME34B8HP ☆ & 8DG □	Rated torque	N-m	0.25	0.42	0.64	0.85	1.3	1.9	2.3	3.4	3.9	3.9
		oz-in	36.11	59.71	90.27	120.82	180.53	263.86	319.40	486.05	555.49	555.49
DME34K8HP ☆ & 8DG □	Rated speed	r/min	143	86.0	57.3	43.0	28.6	17.2	14.3	8.7	6.1	2.7
		Rated torque	N-m	0.32	0.53	0.80	1.0	1.6	2.4	2.9	3.9	3.9
	oz-in		45.31	75.04	113.27	141.59	226.54	339.82	410.61	555.49	555.49	555.49

NOTE
1: Enter the required reduction ratio in the □.
2: *Rotation of gearbox shaft is in reverse of rotation of motor.
3: Enter the required voltage A or B in the ☆.