

DME37

MODEL CODE	VOLTAGE	OUTPUT	CURRENT
SA	12V	4.6W	0.78A
SB	24V	4.6W	0.37A
BA	12V	7.2W	1.01A
BB	24V	7.2W	0.53A
KA	12V	9.2W	1.20A
KB	24V	9.2W	0.60A
JB	24V	17.2W	1.07A

● DIMENSIONS Unit mm(inch)



3-M3 DEPTH 4MAX.
(3-M3 DEPTH 0.157MAX)
P=120° P.C.D=φ 28 ±0.2
(P.C.D=1.102DIA. ±0.00787)

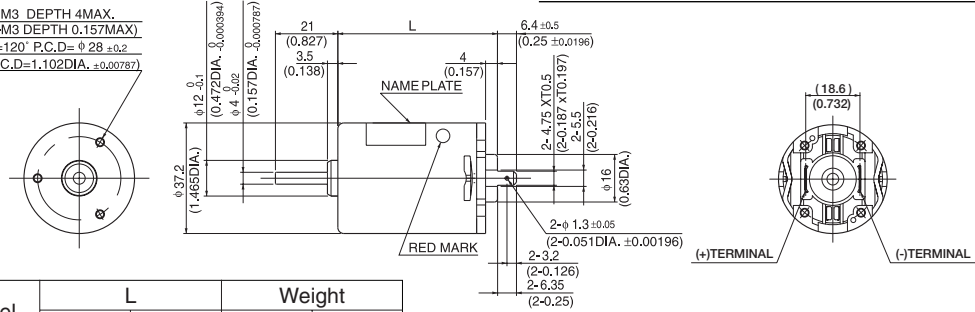

Model	L		Weight	
	(mm)	(inch)	g	lb
DME37SA DME37SB	45.7	1.8	130	0.28
DME37BA DME37BB	53.7	2.11	180	0.40
DME37KA DME37KB	58.7	2.31	210	0.46
DME37JB	63.7	2.51	240	0.53

● CURRENT, SPEED-TORQUE CURVE

DME37SA, DME37SB

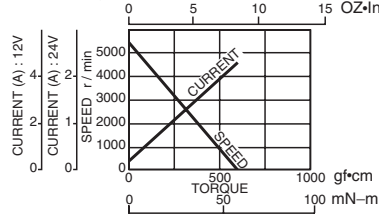

DME37BA, DME37BB

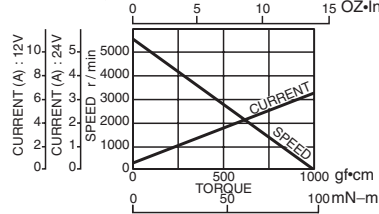

DME37KA, DME37KB

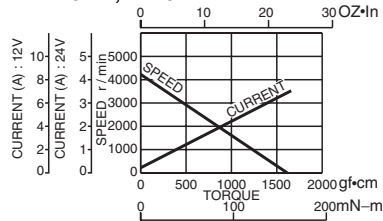

DME37JB

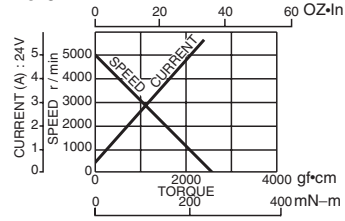

● CONNECTION

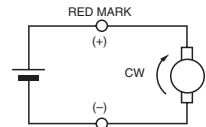

● STANDARD SPECIFICATIONS

Model	Rated					No load		Stall torque		
	Output W	Voltage V	Torque		Current A	Speed r/min	Current A	Speed r/min	mN·m / oz·in	
			mN·m	oz·in					mN·m	oz·in
DME37SA	4.6	12	10	1.42	0.78	4500	0.26	5500	54	7.64
DME37SB	4.6	24	10	1.42	0.37	4500	0.12	5500	54	7.64
DME37BA	7.2	12	15	2.12	1.01	4700	0.25	5500	98	13.88
DME37BB	7.2	24	15	2.12	0.53	4700	0.13	5500	98	13.88
DME37KA	9.2	12	24.5	3.5	1.20	3600	0.27	4300	160	22.66
DME37KB	9.2	24	24.5	3.5	0.60	3600	0.14	4300	160	22.66
DME37JB	17.2	24	39	5.52	1.07	4200	0.18	5000	240	34

WITH GEARBOX 6DGF



6DGF

● DIMENSIONS Unit mm(inch) DME37B6DGF

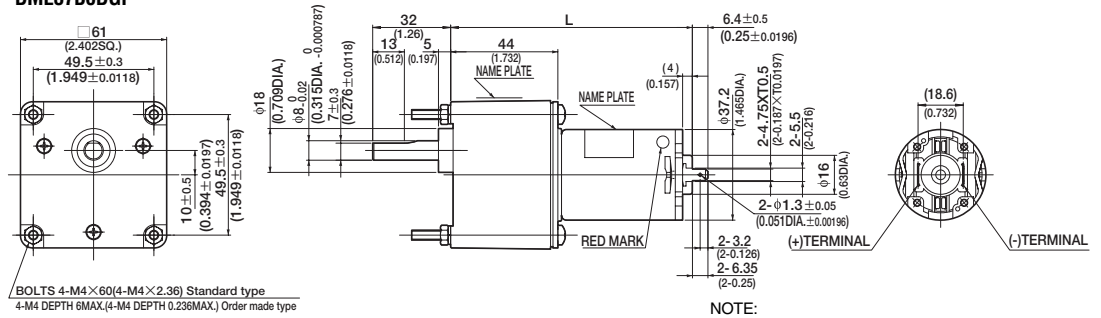

NOTE:

- 6DGF gearbox are available with either 4.5mm diameter mounting holes or M4 x 6mm tapped holes.
- Gearboxes with 4.5mm diameter mounting holes are available from stock. When ordering, please write the motor model and gearbox model numbers separately, as in the following example:
DME37B6HF (Pinion shaft motor)
6DG□F (Gearbox)
- Gearboxes with M4 x 6mm tapped mounting holes are available on request. When ordering, please write the combine motor and gearbox model, as in the following example : **DME37B6HF□B**

● with 6DGF TYPE GEARBOX MOTOR MODEL DME37B6HFP☆, DME37K6HFP☆, DME37J6HFPB & GEARBOX MODEL 6DG□F

Model	Gear ratio		5	*12.5	*15	*25	*30	50	75	100	150	180
	Rated speed	r/min	940	376	313	188	156	94	62.6	47	31.3	26.1
DME37B6HFP☆ & 6DG□F	Rated torque	N-m	0.059	0.13	0.16	0.26	0.32	0.48	0.73	0.96	1.4	1.7
		oz-in	8.33	18.05	22.22	37.50	45.83	68.05	102.76	136.09	194.42	236.08
DME37K6HFP☆	Rated speed	r/min	720	288	240	144	120	72	48	36	24	20.6
	Permission torque	N-m	0.098	0.21	0.26	0.44	0.53	0.8	1.1	1.5	2.3	2.4
oz-in		13.89	30.55	37.5	62.49	74.99	113.88	166.65	222.19	333.29	347.18	
DME37J6HFPB & 6DG□F	Rated speed	r/min	840	336	280	168	140	84	56	42.3	29.9	25.4
	Permission torque	N-m	0.15	0.35	0.42	0.71	0.85	1.2	1.8	2.4	2.4	2.4
oz-in		22.22	49.99	59.71	101.38	120.82	180.53	263.86	347.18	347.18	347.18	

- NOTE**
- 1: Enter the required reduction ratio in the □.
 - 2: *Rotation of gearbox shaft is in reverse of rotation of motor.
 - 3: Enter the required voltage A or B in the ☆.