

DME44

MODEL CODE	VOLTAGE	OUTPUT	CURRENT
SA	12V	9.2W	1.31A
SB	24V	9.2W	0.65A
BB	24V	14.8W	0.94A



● DIMENSIONS Unit mm(inch)

DME44SA, DME44SB

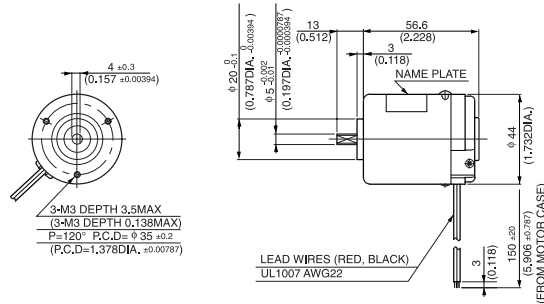

DME44BA, DME44BB

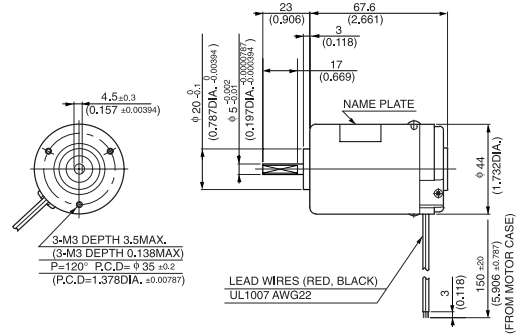

● CURRENT, SPEED-TORQUE CURVE

DME44SA, DME44SB

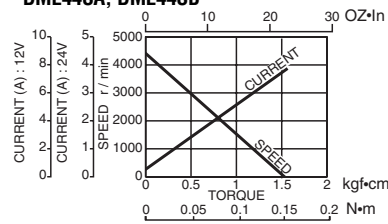

DME44BA, DME44BB

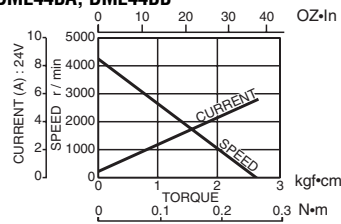

● CONNECTION

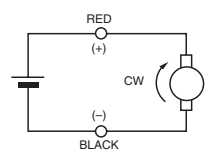

● STANDARD SPECIFICATIONS

Model	Rated					No load		Stall torque		Weight		
	Output W	Voltage V	Torque		Current A	Speed r/min	Current A	Speed r/min	mN-m	oz-in	Weight	
			mN-m	oz-in							g	lb
DME44SA	9.2	12	24	3.47	1.31	3600	0.31	4300	150	22.22	300	0.66
DME44SB	9.2	24	24	3.47	0.65	3600	0.15	4300	150	22.22	300	0.66
DME44BB	14.8	24	39	5.55	0.94	3600	0.16	4300	250	36.11	400	0.88

● REVOLUTION SENSOR MAGNET TYPE

DME44SMA, DME44SMB

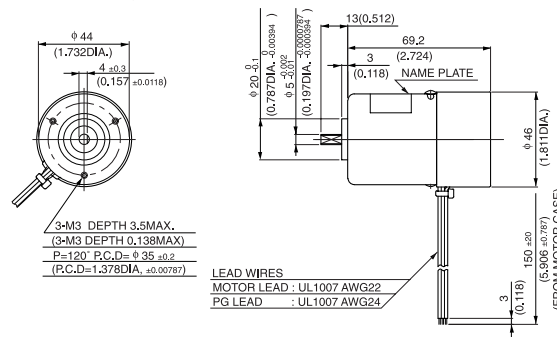

(WEIGHT 400 g 0.88 lb)

● CONNECTION OF REVOLUTION SENSOR

DME44SMA, DME44SMB, DME44BMB

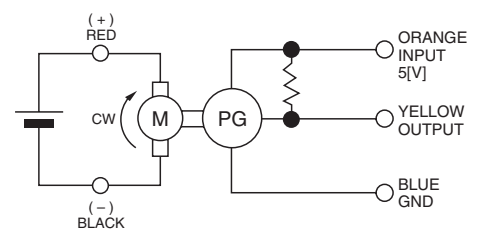

DME44BMB

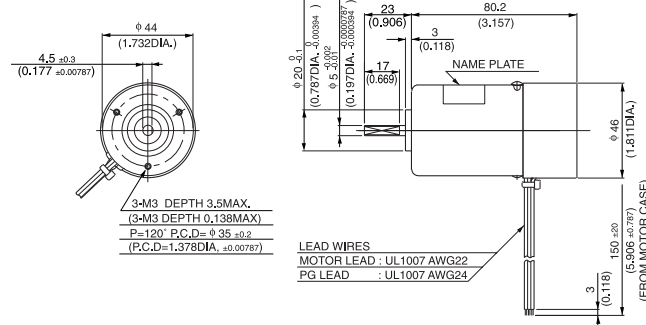

(WEIGHT 500 g 1.1lb)

● SPECIFICATION OF REVOLUTION SENSOR ARE SHOWN ON PAGE 8.

WITH GEARBOX 6DGF



6DGF

●DIMENSIONS Unit mm(inch) DME44S6DGF

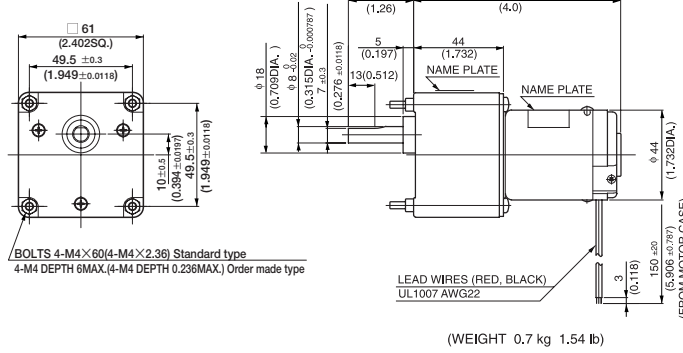

NOTE:
6DGF gearbox are available with either 4.5mm diameter mounting holes or M4 x 6mm tapped holes.
●Gearboxes with 4.5mm diameter mounting holes are available from stock. When ordering, please write the motor model and gearbox model numbers separately, as in the following example:
DME44B6HFPB (Pinion shaft motor)
6DG□F (Gearbox)
●Gearboxes with M4 x 6mm tapped mounting holes are available on request. When ordering, please write the combine motor and gearbox model, as in the following example : DME44B6HF□B

DME44B6DGF

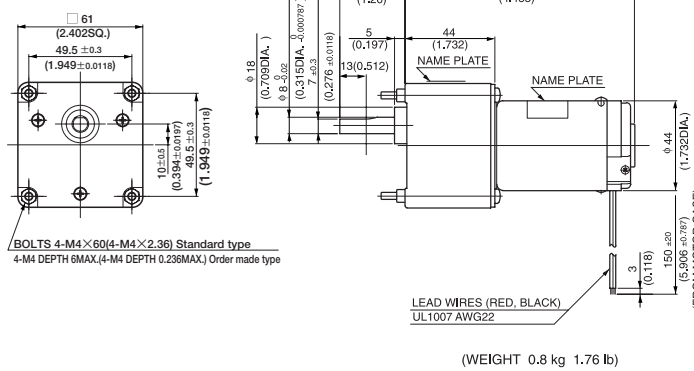

●with 6DGF TYPE GEARBOX MOTOR MODEL DME44S6HFP☆, DME44B6HFPB & GEARBOX MODEL 6DG□F

Model	Gear ratio		5	*12.5	*15	*25	*30	50	75	100	150	180
	Rated speed	r/min	720	288	240	144	120	72	48	36	24	20.6
DME44S6HFP☆ & 6DG□F	Rated torque	N-m	0.1	0.22	0.27	0.44	0.53	0.80	1.2	1.6	2.4	2.4
		oz-in	13.89	30.55	37.50	62.49	74.99	113.87	166.65	222.19	333.29	347.18
DME44B6HFPB & 6DG□F	Rated speed	r/min	720	288	240	144	120	72	48	36.3	25.7	21.8
		Rated torque	N-m	0.16	0.35	0.43	0.72	0.85	1.3	1.9	2.4	2.4
	oz-in		22.22	49.99	59.71	101.38	120.82	180.53	263.86	347.18	347.18	347.18

WITH GEARBOX 8DG



8DG

●DIMENSIONS Unit mm(inch) DME44S8DG

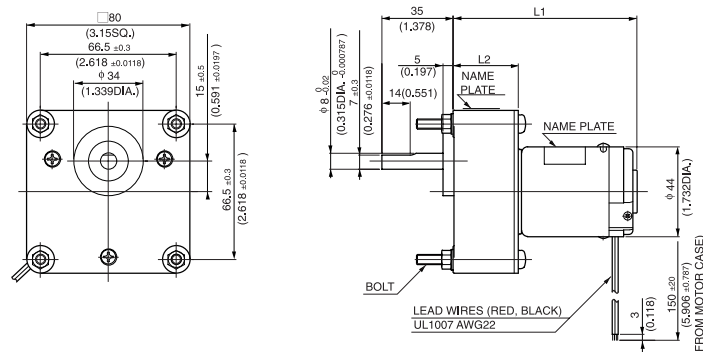

NOTE :
When ordering, please write the motor model and gearbox model numbers separately, as in the following example:
DME44B8HPB (Pinion shaft motor)
8DG□ (Gearbox)

GEAR RATIO	L1		L2		BOLT		WEIGHT	
	(mm)	(inch)	(mm)	(inch)	(mm)	(inch)	kg	lb
30~150	90.1	3.547	32	1.26	M5X50	M5X1.969	0.8	1.76
250~1800	100.1	3.941	42	1.654	M5X60	M5X2.362	0.9	1.98

NOTE 1: Enter the required reduction ratio in the □.
2: *Rotation of gearbox shaft is in reverse of rotation of motor.
3: Enter the required voltage A or B in the ☆.