



Specification

6DG□F	DMN37B6HFP◇			DMN37K6HFP◇			DMN37J6HFPB		
	RATED TORQUE		SPEED	RATED TORQUE		SPEED	RATED TORQUE		SPEED
GEAR RATIO	N·m	oz·in	r/min	N·m	oz·in	r/min	N·m	oz·in	r/min
3	0.035	5.01	1560	0.059	13.5	1200	0.095	13.5	1200
3.6	0.042	5.98	1300	0.072	15.3	1000	0.11	15.3	1000
5	0.059	0.00	940	0.098	22.3	720	0.16	22.3	720
6	0.072	10.2	783	0.12	26.4	600	0.19	26.4	600
7.5	0.089	12.7	626	0.15	33.4	480	0.24	33.4	480
9	0.11	15.3	522	0.18	40.3	400	0.28	40.3	400
※ 12.5	0.13	18.1	376	0.22	50.1	288	0.35	50.1	288
※ 15	0.16	22.3	313	0.26	59.8	240	0.42	59.8	240
※ 18	0.19	26.4	261	0.32	72.3	200	0.51	72.3	200
※ 25	0.26	37.6	188	0.44	102	144	0.72	102	144
※ 30	0.32	45.9	156	0.53	121	120	0.85	121	120
※ 36	0.38	54.3	130	0.64	139	100	0.98	139	100
50	0.48	68.2	94.0	0.80	181	72.0	1.3	181	72.0
60	0.58	82.1	78.3	0.96	209	60.0	1.5	209	60.0
75	0.73	103	62.6	1.2	264	48.0	1.9	264	48.0
90	0.86	122	52.2	1.4	320	40.0	2.3	320	40.0
100	0.96	136	47.0	1.6	348	36.0	2.5	348	36.3
120	1.2	163	39.1	1.9	348	30.0	2.5	348	31.2
150	1.4	199	31.3	2.4	348	24.0	2.5	348	25.7
180	1.7	235	26.1	2.5	348	20.6	2.5	348	21.8

※ Enter the required reduction ratio in the □.

※ Rotation of gearbox shaft is in reverse of rotation of motor.

※ Enter the required voltage A or B in the ◇.

Outline

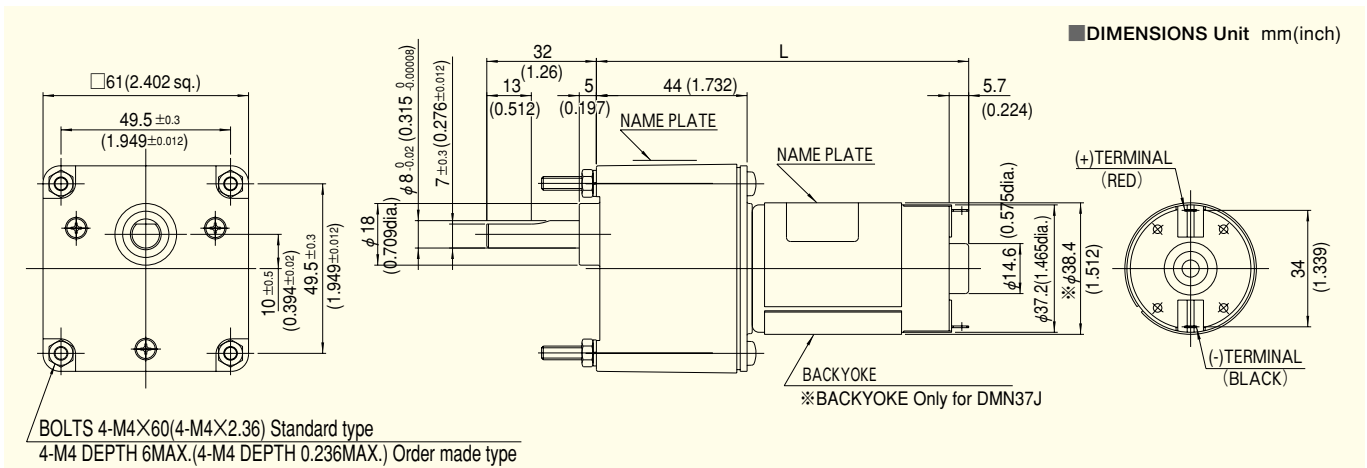

NOTE:

6DGF gearbox are available with either 4.5mm diameter mounting holes or M4 x 6mm tapped holes.

● Gearboxes with 4.5mm diameter mounting holes are available from stock.

When ordering, please write the motor model and gearbox model numbers separately, as in the following example: DMN37B6HFP◇ (Pinion shaft motor) 6DG□F (Gearbox)

● Gearboxes with M4 x 6mm tapped mounting holes are available on request.

When ordering, please write the combine motor and gearbox model, as in the following example : DMN37B6H□F◇

● Enter the required reduction ratio in the □.

● Enter the required voltage A or B in the ◇.

MODEL	L		WEIGHT	
	mm	inch	g	lb
DMN37B6HFP◇+6DG□F	98.7	3.880	580	1.3
DMN37K6HFP◇+6DG□F	103.7	4.083	610	1.3
DMN37J6HFPB+6DG□F	108.7	4.280	640	1.4