

# Palm mini PLUS type



## ■Specification

Model on motor		plain shaft type	FY6S6-D3	FY8S15-D3	FY8S25-D3	FY9S40-D3				
		Pinion shaft type	FY6PF6N-D3	FY8PF15N-D3	FY8PF25N-D3	FY9PF40N-D3				
Model on driver		plain shaft type	FYD66PD3	FYD815PD3	FYD825PD3	FYD940PD3				
		Pinion shaft type								
Rated voltage	V(DC)		24	24	24	24				
Rated output	W		6	15	25	40				
Speed control range	r/min		200~2500	200~2500	200~2300	200~2000				
Rated torque	mN • m		39	98	160	250				
	oz • in		5.6	14	22	36				
MAX. instantaneous torque 5sec	mN • m		59(1500r/min MAX.)	150(1500r/min MAX.)	200(1500r/min MAX.)	300(600r/min MAX.)				
	oz • in		8.3(1500r/min MAX.)	21(1500r/min MAX.)	28(1500r/min MAX.)	43(600r/min MAX.)				
Rated speed	r/min		1500	1500	1500	1500				
Speed setting method		①Speed setting by external speed setter(Sold separately : model code Q-R10KB) ②Speed setting by external voltage supply 0~10V								
Speed setting	(r/min)/V	300±5%								
Speed variation		Against load	±1% 0~rated torque at rated voltage and speed							
		Against voltage	±1% DC24V±10% at rated speed, no load							
		Against temperature	±3% 20±20°C at rated voltage and speed, no load							
Input and output signal		Input	RUN, BRAKE, F/R IN H : Open collector L : GND(0~0.8V)							
		Output	ALARM, SPEED OUT(PULSE OUTPUT), F/R OUT H : Open collector DC30V MAX. L : 0~0.8V 10mA MAX.							
Speed pulse	Pulse/Rotation		30	30	30	30				
Current	Rated (Ave.)	A	0.7 MAX.	1.4 MAX.	2.3 MAX.	3.4 MAX.				
	MAX. (Peak)		4.2 MAX.	6.6 MAX.	10 MAX.	10 MAX.				
Protection		Over load protection When an exceeding torque than rated is applied to motor for more than about 5sec. Stop motor and output "L" from "ALARM".In disconnect power supply for more than 1min, In case of alarm releas.								
Others		Operation temperature 0~40°C(no condensation) continuous duty. The motor flange surfase temp must be 80°C MAX. (Ambient temperature 40°C without heat sink) Motor dielectric strength Withstad for 1min. under AC500V 50Hz (Between case and coil) Motor insulation resistance 10MΩMIN. (Between case and coil DC500V tester)								
Gear ratio	Speed(r/min)		Applicable MAX. Torque for gearheads							
	at 200r/min	at 2500r/min	6H□FBN		8H□FBN		8H□FBN		9H□FBN	
			mN • m	oz • in	mN • m	oz • in	mN • m	oz • in	mN • m	oz • in
5	40	500	160	22	390	56	590	83	980	140
15	13	167	470	67	1200	170	1900	260	3000	430
25	8	100	720	100	1800	250	2800	400	4600	650
30	6.7	83	850	120	2100	290	3400	490	5500	780
50	4	50	1400	190	3100	440	5100	720	8300	1200

- □: rotation of gear head output shaft becomes reverse direction of motor's.
- Other gear ratios than the above table, are also available.

# BRUSHLESS DC MOTOR & SPEED CONTROL DRIVERS

# FYD Series DC24V

## ■ Torque-speed/Current (TYP.) characteristics

### (FY6S6-D3+FYD66PD3)

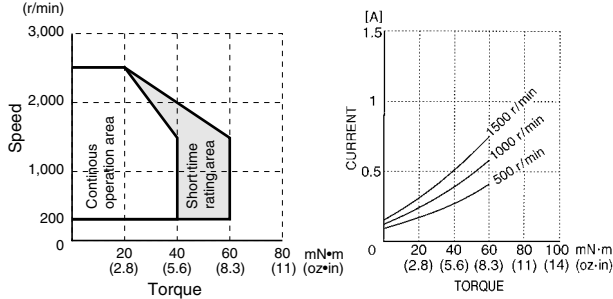

## ■ Motor outlines (Plain shaft type) Unit : mm (inch)

### FY6S6-D3

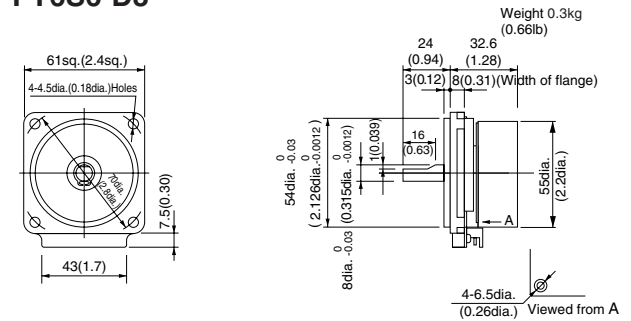

### (FY8S15-D3+FYD815PD3)

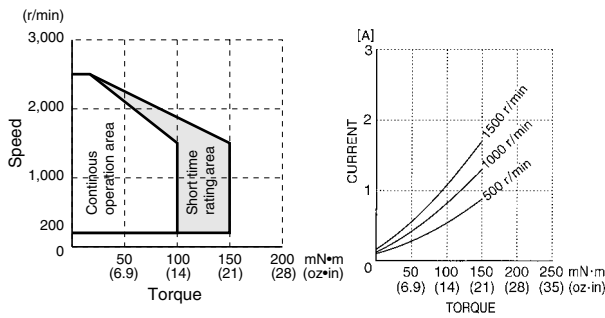

### FY8S15-D3

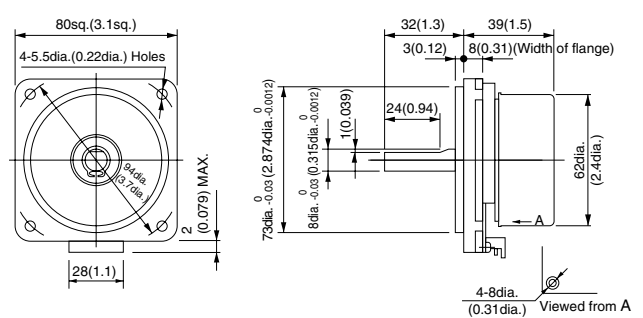

### (FY8S25-D3+FYD825PD3)

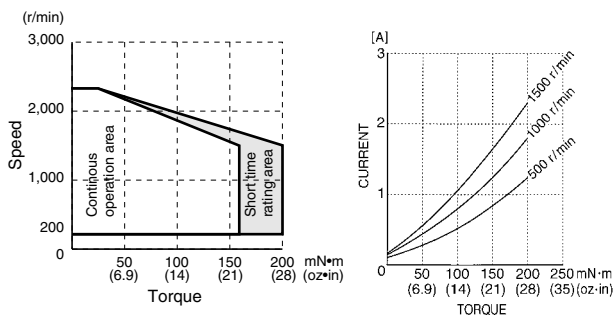

### FY8S25-D3

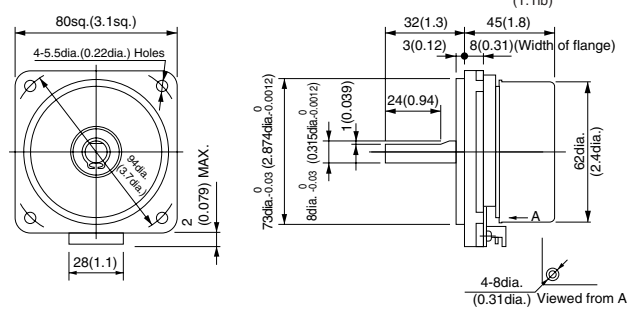

### (FY9S40-D3+FYD940PD3)

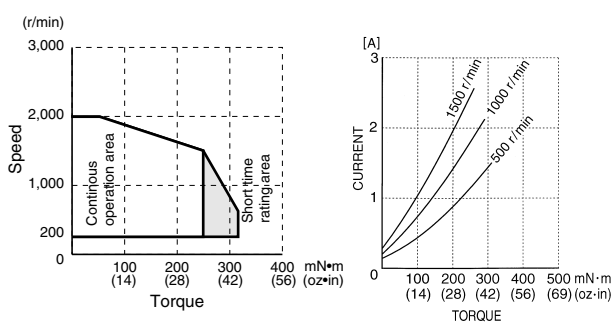

### FY9S40-D3

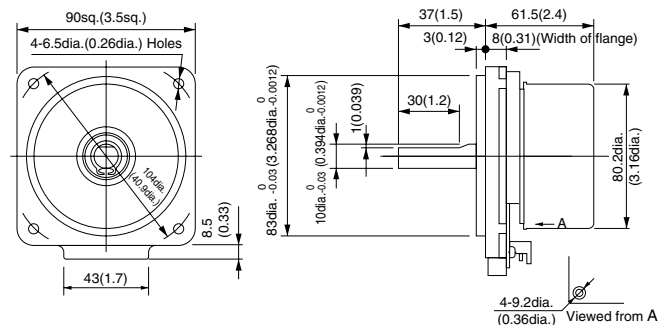

## Motor (Pinion shaft type)+ Gear head outlines

Unit : mm (inch)

### FY6PF6N-D3+ 6H □ FBN

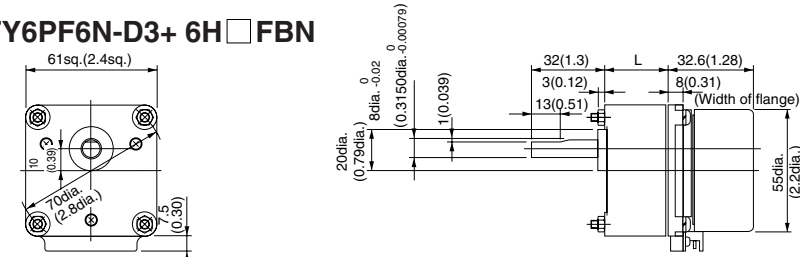

L(Gear head length)•Weight•Screw(Accessory)

Gear ratio	Lmm(in.)	Weight Kg(lb)	Screw
1/5~1/15	32(1.3)	0.4(0.88)	M4X50(2.0)
1/25~1/50	42(1.7)	0.4(0.88)	M4X60(2.4)

### FY8PF15N-D3+ 8H □ FBN

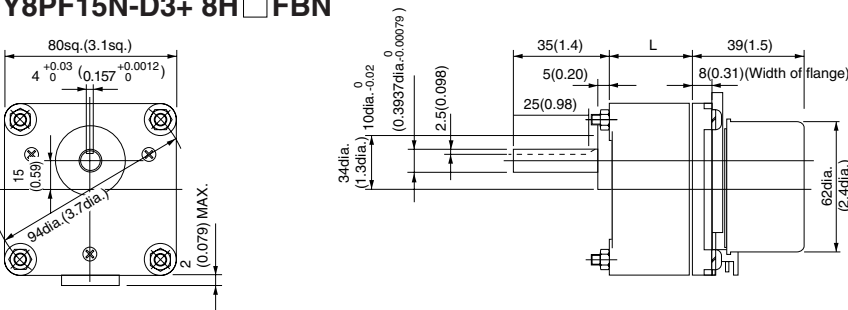

L(Gear head length)•Weight•Screw(Accessory)

Gear ratio	Lmm(in.)	Weight Kg(lb)	Screw
1/5~1/15	30(1.2)	0.5(1.1)	M5X50(2)
1/25~1/50	40(1.6)	0.6(1.3)	M5X60(2.4)

### FY8PF25N-D3+ 8H □ FBN

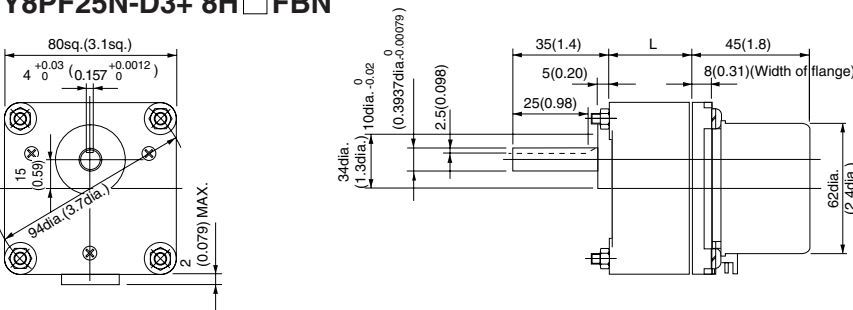

L(Gear head length)•Weight•Screw(Accessory)

Gear ratio	Lmm(in.)	Weight Kg(lb)	Screw
1/5~1/15	30(1.2)	0.5(1.1)	M5X50(2)
1/25~1/50	40(1.6)	0.6(1.3)	M5X60(2.4)

### FY9PF40N-D3+ 9H □ FBN

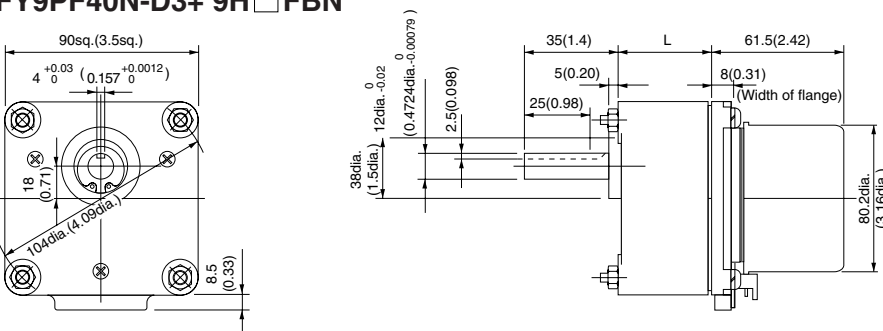

L(Gear head length)•Weight•Screw(Accessory)

Gear ratio	Lmm(in.)	Weight Kg(lb)	Screw
1/5~1/15	42(1.7)	0.8(1.8)	M6X50(2.4)
1/25~1/50	60(2.4)	0.9(2.0)	M6X60(3.1)

#### NOTE

For prevention of oil leaking, combination use a packing (rubber) sold separately between gear head and motor.

Model on packing(rubber)

6H □ FBN : H6packing(rubber)

8H □ FBN : H8packing(rubber)

9H □ FBN : H9packing(rubber)

# Input & output terminals and wiring diagram

Item	Pin No.	Symbol	Input or Output	Function	Standard • Condition
Power supply	1	VM	Input	Power supply positive for driver	DV24V±10%
	2	P.GND	—	Power supply GND for driver	
I/O	1	SPEED OUT	Output	30 Pulse/Revolution *3	*1 H : Open collector DC30V MAX. L : 0~0.8V 10mA MAX.
	2	F/R OUT	Output	H : CCW L : CW (Viewed from motor output shaft end)	
	3	VR	Output	Power supply positive for external speed setter	0~10V
	4	VS	Input	Speed setting signal positive	
	5	GND	—	Speed setting signal GND	
	6	GND	—	GND for I/O Signal	
	7	ALARM	Output	H : Normal operation L : Protective function operates	Same as *1
	8	F/R IN	Input	H : CCW L : CW (Viewed from motor output shaft side)	*2 H : Open collector L : 0~0.8V
	9	BRAKE	Input	H : Brake releases L : Brake operates	H : Open collector L : 0~0.8V During the operation of "BRAKE", "RUN" signal should be "L".
	10	RUN	Input	H : Motor stops L : Motor rotates	Same as *2

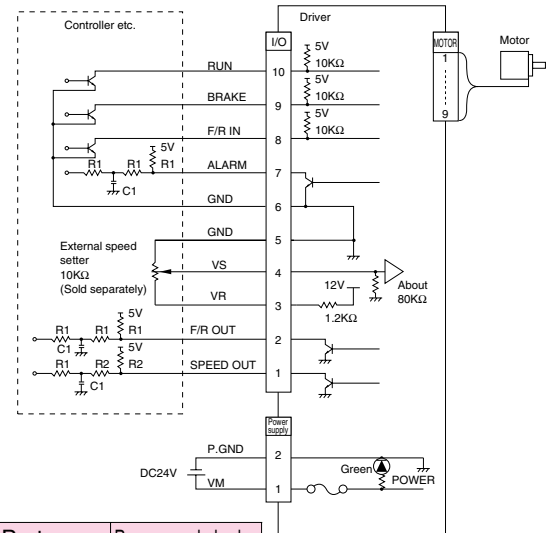

Part name	Recommended value
R1	4.7KΩ
R2	1KΩ
C1	0.01μF

\*3 "SPEED OUT" signal is shown below.

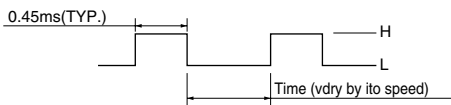

When input signal is H, input signals (RUN, BRAKE, F/R IN) should be input by open collector. If 5V is input, it will become the cause of wrong operation. Noise of output signals (ALARM, F/R OUT, SPEED OUT) should be removed by a filter as shown in figure above. Setting of filter constant should be done by confirming the noise level referring to the recommended constant. At this time, be careful that signal delays if the values of resistance and/or capacitor are big though it becomes better to kill noise. Specially, for speed out, setting should be done with attention to filter constant because pulse width is narrow.

## Control sequence

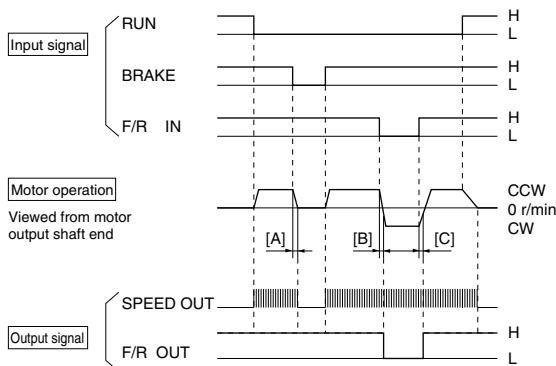

- [Notes for BRAKE Operation & Rotation change]
- (1) During the brake is operating (period [A] left), to change direction of rotation, switch signal of "F/R IN", only after the brake signal was changed to non-operational condition ("L"→"H").
  - (2) During the direction of rotation changing (period [B] & [C] left), you need the brake to operate, let it operate only when the both direction of rotation setting signal ("F/R IN") and direction monitor signal ("F/R OUT") is the same.
  - (3) When actual motor speed is higher than the setting (by signal input value of (VS)), any of signal switching on "F/R IN" and BRAKE ("H"→"L") must not be made.
  - (4) During the brake is operating set the "RUN" signal at "L" all the time.

**WARNING:**  
Notes above must be following without fail, and reminded all the time. But if not follow to (1), (2) & (4), it may cause abnormal/dangerous motor operation, and not follow to (3), it may cause FIRE or system damage.

**Electrical shock :** By the load condition, the terminal voltage (VM) is raised up to 30 VDC, during switching BRAKE and/or Rotation direction.

**(Braking Operation :** At higher speed : reverse rotation brake first, then short circuit brake. But at slower speed : short circuit brake only.)

[Notes on "F/R OUT"]

During the motor is in stop, the "F/R OUT" is held at the same signal as previously outputting. This means ; if the motor stopped once, but the rotation reversed by Cogging torque or by the Load, then the "F/R OUT" is held at reversed signal. Also note that "F/R OUT" signal will delay by 0~5pulses of "SPEED OUT" from the motor rotation switched.

## Speed setting

Fig.1 Speed setting by external speed setter

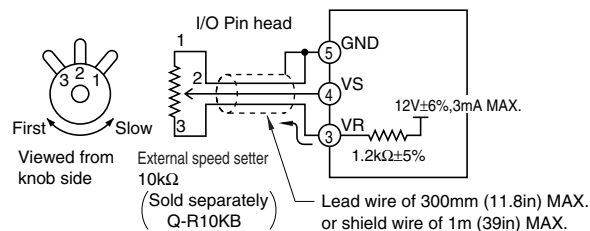
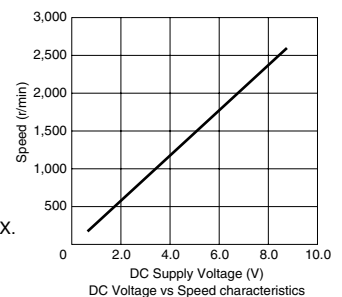
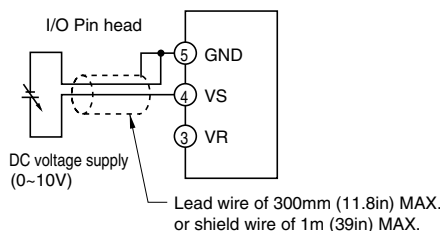

Fig.2 Speed setting by external voltage supply



Item	Setting Method
Speed setting by external speed setter (sold separately)	Connect as shown in Fig.1 and set by external speed setter. Use variable resistor 10[KΩ] as external speed setter.
Speed setting by external voltage supply	Connect as shown in Fig.2 and set speed by external voltage supply.

By these method, it is possible to set a speed at outside of Speed range. But it must be out of our product warranty.

## Protection

Item	Protection		Alarm Release
	Setting	Action	
Overload Protection	When the load exceeding rated torque is applied to motor for more than about 5 sec.	Motor is stopped, and "ALARM" outputs "L".	Disconnect power supply for more than 1 minute.

Do not measure/judge by this operation whether the motor is overloaded or not.

## Driver outline

Unit : mm (inch)

**FYD66PD3, FYD815PD3,  
FYD825PD3, FYD940PD3**

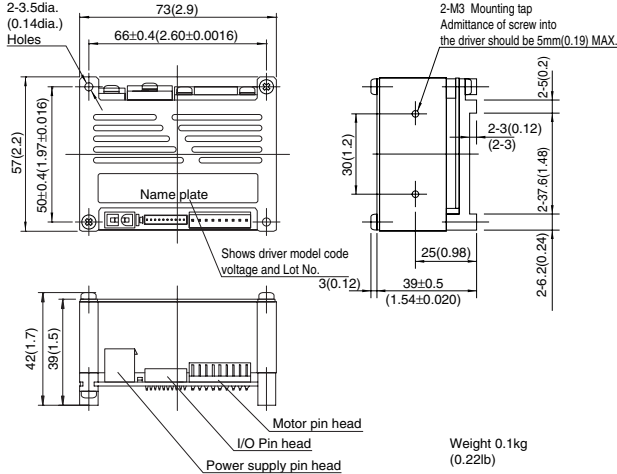

## Rotor cover (Sold separately)

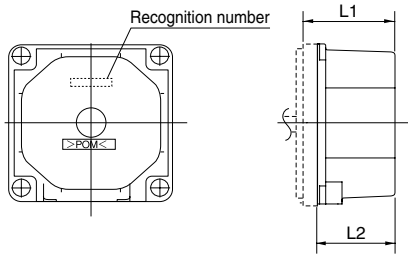

Model on rotor cover	L1mm (in)	L2mm (in)	Recognition number	Accessory washer nominal diameter	Adapting motor	
F-RC630	37 (1.5)	30.4 (1.20)	AD09877	M4	6W	Plain shaft type FY6S6-D3 Pinion shaft type FY6PF6N-D3
F-RC837	43.5 (1.71)	37 (1.5)	AD09768	M5	15W	Plain shaft type FY8S15-D3 Pinion shaft type FY8PF15N-D3
F-RC844	50 (2.0)	43.5 (1.71)	AD09904	M5	25W	Plain shaft type FY8S25-D3 Pinion shaft type FY8PF25N-D3
F-RC961	67.5 (2.66)	61 (2.40)	AD09903	M6	40W	Plain shaft type FY9S40-D3 Pinion shaft type FY9PF40N-D3

## Connector model code

Item	Driver or motor side	Pin head model code on driver or motor	Connector model code on cable		Maker
			Housing	Contact (reel)	
I/O connection	Driver	IL-Y-10P-S15T2-EF	IL-Y-10S-S15C3	IL-Y-C3-A-10000	JAE
Power supply connection	Driver	5566-02A	5557-02R	5556T	MOLEX
Motor connection	Driver	IL-G-9P-S3T2-E	IL-G-9S-S3C2	IL-G-C2-SC10000	JAE
	Motor	IL-G-11P-S3L2-E	IL-G-11S-S3C2	IL-G-C2-SC-1000	

## Accessory

Unit : mm (inch)

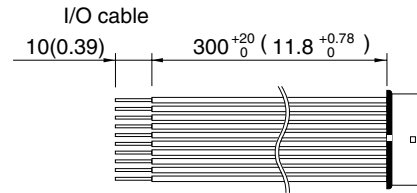

### Connection guide

Pin No.	Name	Lead wire color	Lead wire
1	SPEED OUT	Brown	UL3265 AWG28
2	F/R OUT	Red	
3	VR	Orange	
4	VS	Yellow	
5	GND	Green	
6	GND	Blue	
7	ALARM	Purple	
8	F/R IN	Gray	
9	BRAKE	White	
10	RUN	Black	

### Power supply cable

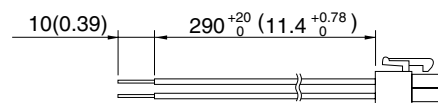

### Connection guide

Pin No.	Name	Lead wire color	Lead wire
1	VM	Red	UL1430
2	P. GND	Black	AWG22

### Motor cable

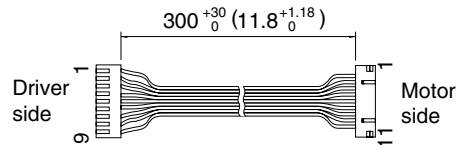

### Connection guide

Motor side connector Pin No.	Driver side connector Pin No.	Name	Lead wire color	Lead wire
1	1	Coil U	Brown	UL1007 AWG24
2	-	-	-	-
3	2	Coil V	Red	UL1007 AWG24
4	-	-	-	-
5	3	Coil W	Orange	UL1007 AWG24
6	4	-	Yellow	
7	5	HW	Green	
8	6	HV	Blue	
9	7	HU	Purple	
10	8	GND	Gray	
11	9	12V	White	

**Motor/Driver/Cable/Rotor cover model code table** Unit : mm (inch)

	Motor model code	Driver model code	Power supply cable model code	Motor cable model code	I/O Cable model code	Rotor cover model code	
<b>FY series</b>	<b>Palm mini PLUS driver</b>	FY6S6-D3	FYD66PD3	FED-CNSL03 300 (11.8)	FED-CNML03 300 (11.8)	FED-CNPL03 300 (11.8)	F-RC630
				FED-CNSL05 500 (19.7)	FED-CNML05 500 (19.7)	FED-CNPL05 500 (19.7)	
				FED-CNSL10 1000 (39.4)	FED-CNML10 1000 (39.4)	FED-CNPL10 1000 (39.4)	
		FY6PF6N-D3	FYD66PD3	FED-CNSL03 300 (11.8)	FED-CNML03 300 (11.8)	FED-CNPL03 300 (11.8)	F-RC630
				FED-CNSL05 500 (19.7)	FED-CNML05 500 (19.7)	FED-CNPL05 500 (19.7)	
				FED-CNSL10 1000 (39.4)	FED-CNML10 1000 (39.4)	FED-CNPL10 1000 (39.4)	
		FY8S15-D3	FYD815PD3	FED-CNSL03 300 (11.8)	FED-CNML03 300 (11.8)	FED-CNPL03 300 (11.8)	F-RC837
				FED-CNSL05 500 (19.7)	FED-CNML05 500 (19.7)	FED-CNPL05 500 (19.7)	
				FED-CNSL10 1000 (39.4)	FED-CNML10 1000 (39.4)	FED-CNPL10 1000 (39.4)	
		FY8PF15N-D3	FYD815PD3	FED-CNSL03 300 (11.8)	FED-CNML03 300 (11.8)	FED-CNPL03 300 (11.8)	F-RC837
				FED-CNSL05 500 (19.7)	FED-CNML05 500 (19.7)	FED-CNPL05 500 (19.7)	
				FED-CNSL10 1000 (39.4)	FED-CNML10 1000 (39.4)	FED-CNPL10 1000 (39.4)	
		FY8S25-D3	FYD825PD3	FED-CNSL03 300 (11.8)	FED-CNML03 300 (11.8)	FED-CNPL03 300 (11.8)	F-RC844
				FED-CNSL05 500 (19.7)	FED-CNML05 500 (19.7)	FED-CNPL05 500 (19.7)	
				FED-CNSL10 1000 (39.4)	FED-CNML10 1000 (39.4)	FED-CNPL10 1000 (39.4)	
		FY8PF25N-D3	FYD825PD3	FED-CNSL03 300 (11.8)	FED-CNML03 300 (11.8)	FED-CNPL03 300 (11.8)	F-RC844
				FED-CNSL05 500 (19.7)	FED-CNML05 500 (19.7)	FED-CNPL05 500 (19.7)	
				FED-CNSL10 1000 (39.4)	FED-CNML10 1000 (39.4)	FED-CNPL10 1000 (39.4)	
		FY9S40-D3	FYD940PD3	FED-CNSL03 300 (11.8)	FED-CNML03 300 (11.8)	FED-CNPL03 300 (11.8)	F-RC961
				FED-CNSL05 500 (19.7)	FED-CNML05 500 (19.7)	FED-CNPL05 500 (19.7)	
				FED-CNSL10 1000 (39.4)	FED-CNML10 1000 (39.4)	FED-CNPL10 1000 (39.4)	
		FY9PF40N-D3	FYD940PD3	FED-CNSL03 300 (11.8)	FED-CNML03 300 (11.8)	FED-CNPL03 300 (11.8)	F-RC961
				FED-CNSL05 500 (19.7)	FED-CNML05 500 (19.7)	FED-CNPL05 500 (19.7)	
				FED-CNSL10 1000 (39.4)	FED-CNML10 1000 (39.4)	FED-CNPL10 1000 (39.4)	

NOTE) Cable types for FYD series are the same as FED series, because they are used in commonly.